

## ELECTRICAL STRIP HEATER



The Electrical Strip Heater (ESH) is an electric resistance heater that slides into the fan coil on the leaving air side (supply side) of the blower. This heater can be used for primary heating or supplemental heat (auxiliary heating) for heat pumps. The ESH has “0” clearance to combustibles, and requires minimum clearances on the access side for maintenance and servicing (see Fan Coil Placement: Module FCP). Allow 18” minimum of straight plenum duct from the supply of the air handler before any branch outlets, tees or elbows.

There is a minimum air flow requirement for the electric strip heater:

The HE-50 and the HE-70 require a minimum of six 2”x10’ AFD outlets per 5 kW.

The HE-100 requires a minimum of seven 2”x10’ AFD outlets per 5 kW.

\*One HE x 10’ AFD is equivalent to two - 2” x 10’ AFDs

### INSTALLATION

Remove the shipping covers and inspect the heater carefully. Check the ESH for any shipping damage, check the heating elements for any loose connections and check all porcelain insulators for any breaks. Report any damage to the manufacturer. **DO NOT INSTALL DAMAGED HEATER.**



The ESH is labeled with a directional airflow sticker; when placing the ESH, the sticker shall be in the direction of the air flow.

Install the ESH in the supply air side of the fan coil. Remove the coil access door and simply slide the coil into place. The heating elements (**Fig. 01**) must always be installed horizontally. Seal the void between the fan coil and the ESH with the foam tape supplied with the unit or with a suitable sealant. Mount the ESH onto the fan coil cabinet with 4 self tapping screws from inside the ESH wiring access door. Seal any additional openings with a suitable sealing compound.

**Fig. 01 - Do not install elements Vertically**

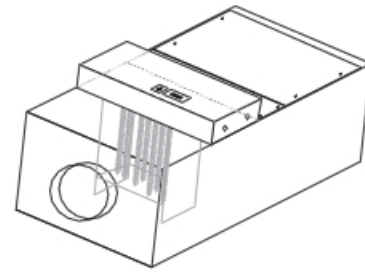

ELEMENTS ARE TO BE INSTALLED  
HORIZONTALLY, NOT VERTICALLY

### WIRING THE ELECTRICAL STRIP HEATER

The air handler and the ESH must have independent power supplies. **Disconnect all power sources before opening the control box and working within.** Wires shall be sized according to local electrical codes and ordinances. All wires must be brought in through knock-outs. See Table 01 for feeder quantity of feeder ampacity.

Table 01			
Kw	Volts/ Phase	# of feeders	Circuit Breakers
5	240/1	1 X 20.8	1 X 30A
10	240/1	1 X 41.6	1 X 60A
15	240/1	1 X 20.8 1 X 41.6	1 X 30A 1 X 60A
18	240/1	1 X 31.2 1 X 41.6	1 X 40A 1 X 60A
20	240/1	2 X 41.6	2 X 60A
23	240/1	2 X 47.0	2 X 60A

**PLEASE NOTE: THE ESH MUST BE WIRED TO A DEDICATED BREAKER, SEPARATE FROM THE FAN COIL.**

The ESH elements are rated for 240V 60 Hz. Higher voltages are not recommended. When lower voltages are supplied, de-rate the capacity of the ESH accordingly. 230V = 92%, 220V= 84%, 208V = 75%. Use only wires suitable for 167° F (75°C).

The ESH 5 and 10 kW units have one single 240V breaker; the 15 kW to 23 kW units come complete with two supply circuit breakers. These two circuits can be joined together using a Jumper Bar (Square D® – QOU14100JBAF, not supplied) designed to use one pair of larger gauge wire instead of two smaller gauge wires. Install as per manufacturers guide lines, and according to code. A disconnect switch close to the heater will be required.

Control circuit wiring between the heater terminals #1 and #2 on the ESH use Class 2 - 18 gauge wire to the zone valve terminals in the fan control box.

## OPERATION

The low voltage signals that energize the ESH come from the air handler's zone valve terminals (Z1 and C). These are to be connected to #1 and #2 of the ESH. Note: This connection is polarity sensitive. The Z1 is energized with 24v with a call for heat from a W2 call on the air handler's terminal board. W2 will also energize the heating fan speed on the air handler. For air handler to ESH low voltage wiring, see page \_\_\_ of this manual. High voltage wiring of the ESH can be viewed on the inside of the ESH front panel.

On a demand for heat the TH-24 electronic sequencer will energize the heating elements in sequence. When the thermostat is satisfied, all the elements and blower will be de-energized.

Within the ESH, there are automatic reset thermal cut-out disc type safety devices at a fixed temperature that open the control circuit when a set point is reached. When the overheating conditions have disappeared, it automatically resets and returns the heater to normal operating conditions.

## ZONING

The standard off the shelf ESH has a minimum of outlets per kW that is required to be running for air flow. Energy Saving Products Ltd. also offers a special electric strip module for zoning capabilities. Please contact the factory for additional information.

## MAINTENANCE

ESH heaters have been designed to operate long term without issue. Those responsible for equipment and maintenance should be aware of the following suggestions:

**Periodic visual inspection:** This precautionary step will help to keep your unit operating properly. Inspect the unit periodically and be on the lookout for any first signs of problems: Accumulation of dust on the heating elements, signs of overheating on the heater frame, traces of water or rust on the control box.

**Electrical inspection:** Two weeks after start up, all electric connections to contactors should be re-checked and tightened. Before each heating season, the following steps are recommended:

- Check all fuses
- Check resistance to ground for each circuit
- Check resistance phase to phase for each circuit
- Check the tightness of connections at all contactors and heating elements
- Check all contactors
- Check electrical connections to heating elements, magnetic contactors, and main power plugs.

It is recommended that this inspection be performed monthly for the first four months of operation. Following that, two inspections per heating season is sufficient.

## OFF SEASON MAINTENANCE

Should a heater be shut off for a long period, we recommend that you carefully check the resistance to ground for each circuit. It is important not to power a heater when too low a resistance to ground has been measured. It is also recommended to pay attention to any other heater operating in normal conditions. All control components should be maintained and checked according to respective manufacturer's instructions. Any defective components should be replaced only with identical origin parts.

## Specifications

Specifications		ESH - 650	ESH - 750	ESH - 1100
Matching Fan Coil		HE - 50 / 51	HE - 70 / 71	HE - 100 / 101
<b>Part Numbers</b>		5kw - 10025650005	5kw - 10025750005	10kw - 10025110010
		10kw - 10025650010	10kw - 10025750010	15kw - 10025110015
		15kw - 10025650015	15kw - 10025750015	18kw - 10025110018
			18kw - 10025750018	20kw - 10025110020
				23kw - 10025110023
<b>Volts</b>		240	240	240
<b>Phase</b>		1	1	1
<b>Shipping Weight</b>		21 lbs (9.5kg)	27 lbs (12kg)	28 lbs (13kg)
<b>Module Size</b>	Length	20" (508mm)	24" (610mm)	31" (788mm)
	Width	13" (330mm)	13" (330mm)	13" (330mm)
	Height	18" (457mm)	18" (457mm)	18" (457mm)

## ELECTRICAL STRIP HEATER (ESH) WIRING DIAGRAM

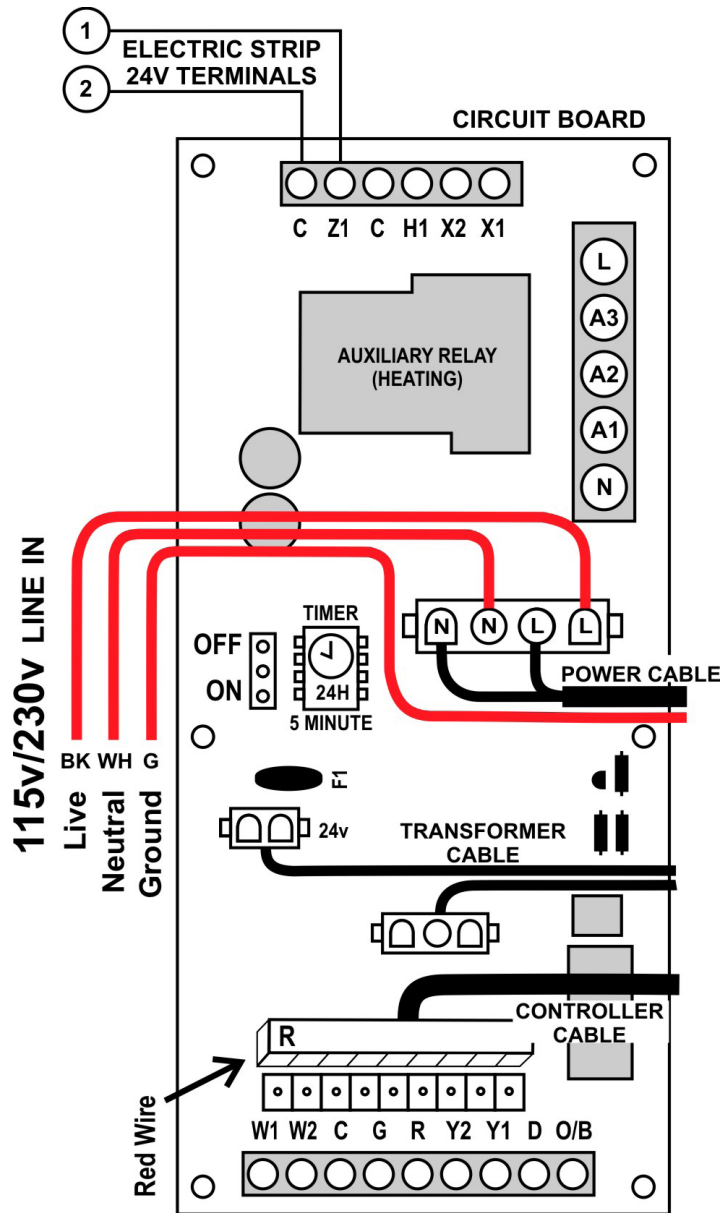

- N - NEUTRAL
- L - LINE VOLTAGE
- A1 - AUXILIARY NORMALLY OPEN
- A2 - AUXILIARY NORMALLY CLOSED
- A3 - AUXILIARY COMMON
- X1 - FREEZE STAT TERMINAL
- X2 - FREEZE STAT TERMINAL
- H1 - CONDENSING UNIT 24V OUTPUT
- C - CONDENSING UNIT 24 VAC COMMON
- Z1 - HEATING MODE 24V OUTPUT
- C - HEATING MODE 24V VAC COMMON

**CAUTION**  
DISCONNECT THE ELECTRIC POWER BEFORE SERVICING

**ATTENTION**  
DECONNEXER DU CIRCUIT D'ALIMENTATION ELECTRIQUE AVANT L'ENTRE-TIEN

### MINIMUM FACTORY DIP SETTINGS BLACK IS DIP SWITCH SETTING

HE-50 5-10 kW  
(1 1/2 Ton Dip Setting)

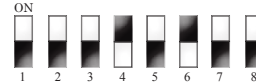

HE-50 5-15 kW  
(2 Ton Dip Setting)

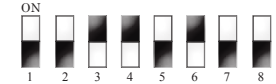

HE-70 5-15 kW  
(2 1/2 Ton Dip Setting)

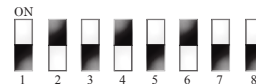

HE-70 5-18 kW  
(3 Ton Dip Setting)

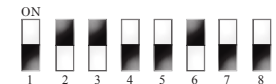

HE-100 10-18 kW  
(3 1/2 Ton Dip Setting)

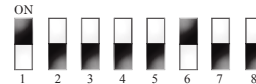

HE-100 10-20 kW  
(4 Ton Dip Setting)

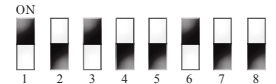

HE-100 10-23 kW  
(5 Ton Dip Setting)

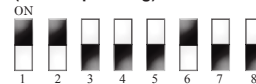

### NOTES:

1) USE THERMOSTAT FAN SWITCH TO DISABLE/ENABLE CONTINUOUS FAN.

2) 'C' TERMINAL ON THERMOSTAT (COMMON) IS NOT NEEDED FOR SOME THERMOSTATS. CONSULT THERMOSTAT INSTRUCTIONS FOR DETAILS.

3) A3 (AUXILIARY RELAY COMMON) CAN BE USED WITH A1 AND/OR A2 AS DRY CONTACTS, ARMED 24v FROM THE 'R' TERMINAL, OR ARMED FROM THE 'L' TERMINAL.

4) AUXILIARY RELAY TIMER ACTIVATES CIRCUIT FOR 5 MINUTES EVERY 24 HOURS STARTING WHEN POWER IS APPLIED TO THE UNIT. RED LIGHT IS ON WHEN AUXILIARY RELAY IS ACTIVATED.

5) SEE INSTALLATION MANUAL FOR MORE DETAILED WIRING DIAGRAMS AND DIP SWITCH SETTINGS.

6) FAILURE TO READ AND FOLLOW ALL INSTRUCTIONS CAREFULLY BEFORE INSTALLATION COULD CAUSE PERSONAL INJURY AND/OR PROPERTY DAMAGE.

### HEAT PUMP NOTES:

DEPENDING ON THE REVERSING VALVE, SOME HEAT PUMP UNITS REQUIRE 'B' INSTEAD OF 'O' CONNECTION ON BOTH THE THERMOSTAT AND THE OUTDOOR UNIT. CONSULT YOUR HEAT PUMP MANUAL TO SEE IF THIS IS REQUIRED.

TIMER CIRCUIT CAN BE DISABLED WHEN USING A HEAT PUMP AND ELECTRIC BACKUP HEAT.

# OPTIONAL WIRING FOR ELECTRICAL STRIP HEATER (ESH)

- 1 Stage Heating (Electric Strip)
- 1 Stage Cooling
- 1 Constant Low Speed

## OPTIONAL WIRING FOR HIGHEST FAN SPEED FOR HEATING AND COOLING

For highest blower speed on the fan coil for heating and cooling, set the thermostat to electric mode instead of gas. Wire the G terminal from the thermostat to the Y2 of the fan coil. When there is a call for heat or cool the fan will run at its highest dip setting air flow. For constant low fan speed control wire a switch (light switch or a toggle switch) at the fan coil between R and G. When the thermostat is not calling for heating or cooling and the fan switch is in the ON position the fan will operate at half the fan speed for constant fan circulation.

Note: This wiring is not required for heat pump set ups, as Y2 is activated for both heating and cooling.

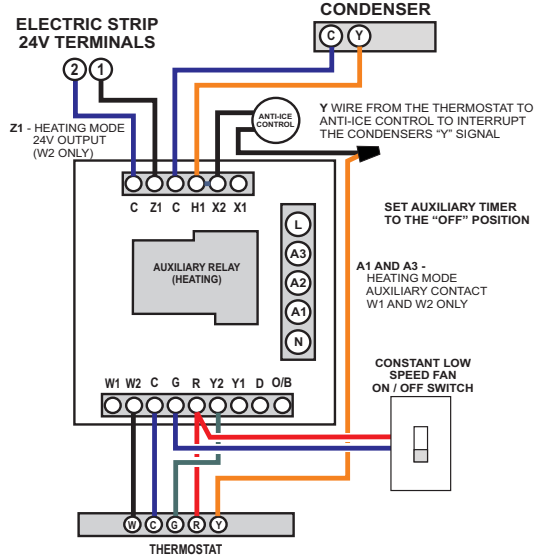

## OPTIONAL STAGING THE 15-23 KW UNITS THROUGH OUT DOOR THERMOSTAT

For optional energy savings install a outdoor thermostat to limit the use of the second stage of the ESH. For example - 2 staging the electric strip interrupt "C" and "1" or "C" and "2" with a outdoor stat as shown below. This allows single stage of the two banks of the electric strip to activate, the second stage will be allowed to activate by the outdoor stat.

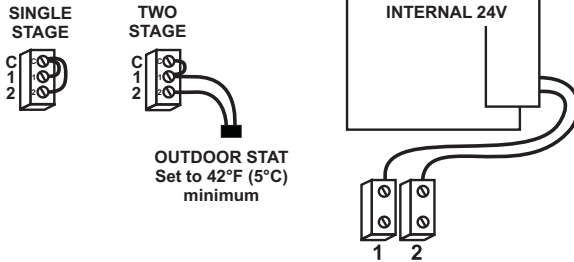

## 1 Stage Cooling 2 Stage Heating Heat pump c/w condenser defrost cycle

### OPTIONAL STAGING THE 15-23 KW UNITS THROUGH THERMOSTAT

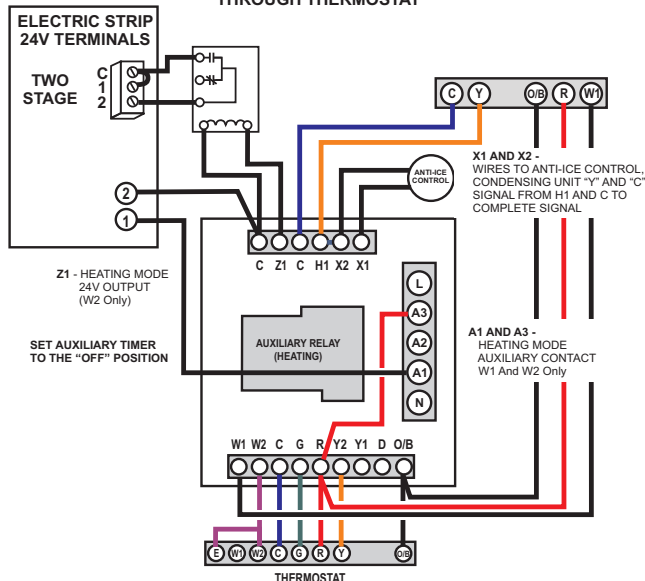

## 2 Stage Heating

### OPTIONAL STAGING THE 15-23 KW UNITS THROUGH THERMOSTAT

