

## RETURN AIR

When designing the return air for a Hi-Velocity System, there are a few things to consider. It is common to use centralized return air with systems that have rooms that are within a common area. Separate floors or rooms that have high loads and require a large amount of supply air flow should have their own return air, or be tied into the centralized return air to allow the air to return back to the fan coil. Rooms or areas that cannot be tied into the return air should have an air transfer grill to allow the air to escape the room and flow back to a centralized return air.

The Hi-Velocity System is a pressure supply duct system that forces the air into rooms through supply outlets. A closed room will pressurize, and air will escape through the undercut of a door back to a centralized return air. (i.e. a typical bedroom with two outlets will deliver 64 cfm into the space, a 1/2" undercut door will provide 15 square inches of r/a from the space at a transfer velocity of 4 fpm, sufficient to provide comfortable r/a.) If more than four 2" or two HE vents are installed in a room, or if there is a sealed door in the room, an air transfer grill or return air should be installed to allow the air back to the fan coil.

The return air duct is not supplied with the Hi-Velocity System. It is to be supplied and installed by the contractor. The return air and fresh air make-up ducts are to be installed according to local building code.

The return air duct from the air handling units is to be acoustically lined for sound absorption, for the first five feet, or for the line of sight. This only applies on short return air duct work of less than 10 feet (3.05m).

### DUCT SIZING

The return air is to be sized on a 0.15 static pressure (37 pa) as compared to 0.10 static pressure (25 pa) for conventional forced air systems. The maximum length for an individual return air duct is fifty feet (15.24m).

**PLEASE NOTE: IT IS VERY IMPORTANT NOT TO UNDERSIZE THE RETURN AIR, AS THIS CAN CREATE NOISE AND INCREASE MOTOR POWER CONSUMPTION**

**Table 01** has recommended return air sizes for round and rectangular ducts. A variance of **plus 20%** is allowable for sizing return ducts that connect to the Hi-Velocity Systems unit.

**Table 01 – Return Air Duct Sizes**

Unit	Round Duct	Rect. Duct Equiv. in Sq. Inches (Sq. cm)
HE-50/51/52	12" (305mm)	120 (774cm)
HE-70/71	12" (305mm)	120 (774cm)
HE-100/101	14" (356mm)	168 (1084cm)

It is recommended to install a grill that is 10 - 20% larger than specifications require, this will ensure that there is no air velocity noise at the grill. Where allowed by local codes, a single return air grill may be used.

**IMPORTANT: WHEN USING FLEXIBLE DUCT FOR RETURN AIR, USE ONE DUCT SIZE LARGER DUE TO THE HIGHER FRICTION LOSS.**

### RETURN AIR CUTOUT

Once the placement of the return has been decided, the return air knockout(s) can be cut. (**Fig. 01**) The pre-measured guide cuts supplied with the fan coil should always be used; this will guarantee maximum airflow across the coil.

**Fig. 01 - Return air cutout**

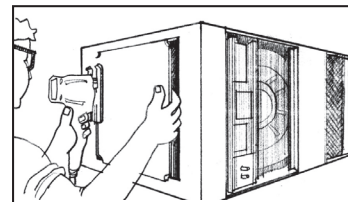
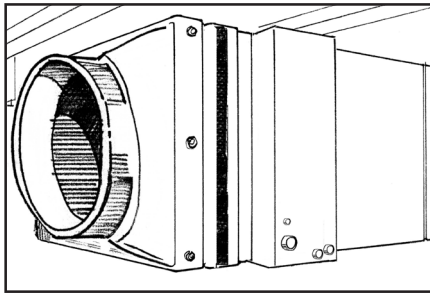

**Table 02 – Return Air Cutout Dimensions**

Model	Dimensions
HE-50/51 H/BU	9 <sup>1/2</sup> " X 13 <sup>1/2</sup> " (241mm X 343mm)
HE-70/71 H/BU	14" X 13 <sup>1/2</sup> " (356mm X 343mm)
HE-100/101 H/BU	20" X 14" (508mm X 356mm)

Once the return air has been cut out, a transition will be needed to attach the return air duct to the fan coil (**Fig. 03**).

**Fig. 02 – Return Air using a transition**



A round or square return air duct can be used; they must be sized for the Hi-Velocity Systems according to **Table 01**. Before the return air can be attached to the transition, the first five feet (from the fan coil) is to be acoustically lined for sound absorption.

## RETURN AIR BASE

Energy Saving Products manufactures a return air base with a built in filter rack that matches up to the fan coil units.

The return air base comes complete with a one-inch (25mm) filter and one-inch (25mm) filter rack. The filter is a 3 medium filter approximately 14% efficient, and can be replaced with any aftermarket filter. All the Return Air bases come acoustically lined with half-inch sound absorbing insulation.

For filter options and other Add-Ons available from Energy Saving Products, see **Module OPT - Options and Add-Ons**.



**Table 03 – Return Air Base dimensions**

	A	B	C	D	E
HE-50/51/52	24" (610mm)	18½" (470mm)	14½" (368mm)	1⅛" (28.6mm)	21¾" (552mm)
HE-70/71	24" (610mm)	18½" (470mm)	19½" (495mm)	1⅛" (28.6mm)	21¾" (552mm)
HE-100/101	24" (610mm)	18½" (470mm)	25½" (648mm)	1⅛" (28.6mm)	21¾" (552mm)

**Fig. 03 - Return Air Design**

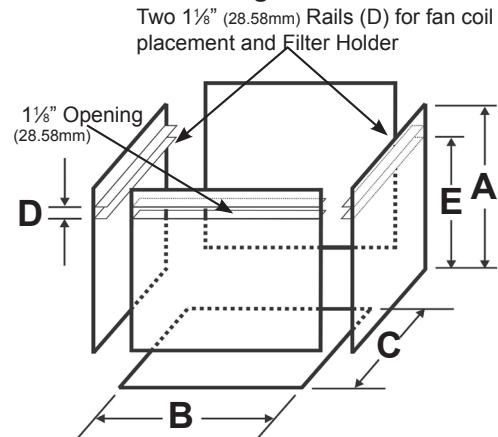

For installation of Heating and Cooling Add-Ons, Refer to:

- **Module RPM - Refrigerant Module Installation**
- **Module HWC - Hot Water Coil Installation**
- **Module WCM - Chilled Water Coil Installation**
- **Module ESH - Electric Strip Coil Installation**

These manuals are included with the coils, and are also available online at [www.hi-velocity.com](http://www.hi-velocity.com).

## MOUNTING ADDITIONAL COMPONENTS

When mounting additional components onto the back of the unit, (Filter Rack, Return Air Base etc.) the hex head (a) screws (4 or 6 depending on unit size) can be replaced with flat head (b) screws for a flush fit.

