

CHILLED WATER COIL (WCM/WM)



The **WCM/WM** coil is a High Capacity Hydronic Water Coil available as an add-on module to the Hi-Velocity System. Mainly used in the chilled water applications for cooling, this coil can also be used for heating with water temperatures up to 130°F (54°C).

INSTALLATION

The coil comes as a module and must be installed in the vertical position on the return air side of the fan coil. The WCM/WM come supplied with two L mounting brackets for connection to the fan coil (**Fig. 01**). When mounting the cooling coil, ensure that no screws puncture the drain pan or coil.

Fig. 01 - Mounting the WCM/WM

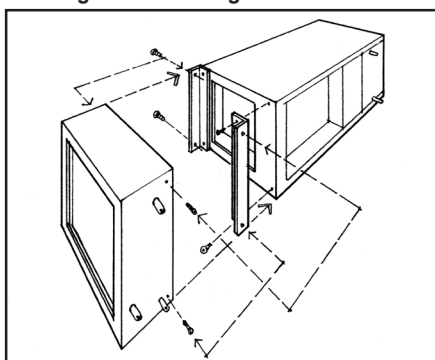

PIPING THE WCM/WM

The WCM comes complete with 2 built-in 3/4" (19mm) drain lines, primary and secondary. Ensure the primary drain line is vented and P-trapped.

The use of a mixture of glycol will reduce capacities; refer to glycol manufacture reduction charts.

When the potential for gravity flow of the hot water exists, check valves may be needed on both the supply and return lines. All lines should be piped so as not to restrict access to the front panels, filter section, or electrical enclosure. Size your supply and return lines according to **Table 01**.

Table 1 - WCM/WM pipe sizing

Zone BTUH	Pipe Size up to 40 feet	Pipe Size 40 – 100 feet
0 - 35,000 (0 - 10.3 kW)	3/4" (19mm)	3/4" (19mm)
35,001 - 70,000 (10.4 - 20.5 kW)	3/4" (19mm)	1" (25mm)
70,001 - 140,000 (20.6 - 41 kW)	1" (25mm)	1 1/4" (32mm)

Specifications

WCM - 50

WCM - 70/1050

WM - 100/1050

WM - 1750

Matching Fan Coil	HE/HV-50/51/52 LV-50	HE/HV-70/71 LV-70 LV-E-1050	HE/HV-100/101 LV-120/140 LV-E-1050	LV-E-1750
Part Number	10010201050	10010201070	10010201100	20090101750
Fin Material	Aluminum	Aluminum	Aluminum	Aluminum
Tubing Material	Copper	Copper	Copper	Copper
Type of Fins	.006 Al (0.1524mm)	.006 Al (0.1524mm)	.006 Al (0.1524mm)	.006 Al (0.1524mm)
Flow Rate (GPM)	5 (0.32 L/s)	7 (0.44 L/s)	10 (0.63 L/s)	10 (0.63 L/s)
Hydronic Connection Sizes	Supply Line	3/4" (19mm)	3/4" (19mm)	1 1/8" (29mm)
	Return Line	3/4" (19mm)	3/4" (19mm)	1 1/8" (29mm)
	Drain Connection	3/4" (19mm)	3/4" (19mm)	3/4" (19mm)
Pressure Drop FT. H₂O	3 (9.0 kPa)	6.5 (19.4 kPa)	6.8 (20.3 kPa)	4.9 (14.65 kPa)
Shipping Weight	30 lbs (14 kg)	35 lbs (16 kg)	40 lbs (18 kg)	45 lbs (20 kg)
Module Size (L x W x H)	14 3/8" x 10 1/8" x 18 1/2" (365mm x 257mm x 470mm)	19 3/8" x 10 1/8" x 18 1/8" (492mm x 257mm x 460mm)	25 3/8" x 7" x 18 3/8" (645mm x 178mm x 467mm)	26 1/4" x 8" x 22 5/8" (656mm x 203mm x 575mm)
BTUH 80°/67° @ 42°F E.W.T. (27°/19 @ 5.5°C E.W.T.)	18,000-24,000 (5.3-7.0 kW)	30,000-36,000 (8.8-10.6 kW)	42,000-60,000 (12.3-17.6 kW)	42,000-70,000 (12.3-20.5 kW)

Module WCM Chilled Water Coil (WCM/WM) (1/1)