

The **Hi-Velocity Systems Zoning Fan Coil** features a superior design with simple setup options. Pre-wired multi-zone controls with adjustable power open and power closed actuators make it easy to understand and set up our zoning system. The fan coil can also be used with any off-the-shelf 24v thermostats.

The **HE-Z Zoning Package** is designed for continuous air circulation when the thermostat is satisfied, allowing for increased filtration more even air temperatures and fresh-air make-up at all times. Hi-Velocity Systems sets another high standard and energy efficiency in the residential & light commercial Forced Air Zoning Industry.



Page Breakdown

1. Introduction
2. Dip settings and Timer Breakdown
3. Zone LED Indications
4. Zone Control Breakdown
5. Zone Dampers and take-offs
6. Damper Actuator, Constant Fan
7. Zone Control Wiring
8. 120v Wiring
9. 220v Wiring
10. 120v and 240v Wiring Continuation

Zoning Controls Features

Adjustable Zone Dampers - Power Open and Power Closed zone dampers are pre-wired and installed on the fan coil.

Zone Capacity - The main module controls three zones using motorized dampers and may be expanded to 4 or 5 zones.

Compatible Controls - Controls single or two-stage hydronic heating systems, with single or two stage air conditioning.

Thermostats - Compatible with off the shelf 24v Heat/Cool Thermostats. Example (1heat/1cool) or (2heat/1cool).

Automatic Heat/Cool Changeover - Automatic changeover from any thermostat allowing for individual zone comfort.

Status LED - A green STATUS LED pulses as a steady heart beat to indicate Micro- processor activity and 24v power is present

System LEDs - Function specific colored LED's illuminate to indicate the HVAC system mode of operation and active zone identification. See Page 3 for details.

Damper LEDs - Green LEDs labelled Zone 1 thru Zone 5 indicate which dampers are energized to the open position.

Constant Fan Control - Any zone can activate the indoor fan and only the dampers in zones calling for continuous fan operation will open. Continuous fan operation will only occur when there are no active or pending, heat or cool demands.

Internal Fuse (F1)- CAUTION: When the Internal Fuse is tripped it will get quite hot. To reset the Fuse: Shut off power to the fan coil and find and repair the short. Restore the 24VAC power.

Selecting the Options Using the DIP Switches

Programming and Setting up your HVAC System

Review each pin setting explanation of each dip switch function and choose your settings for correct operations. Some functions may not apply to your application.

** Push the reset button for 7 seconds whenever there is a change the dip settings to reset the CPU.

	ON		DEFAULT
1	<input type="checkbox"/>	HP < SYSTEM > OTHER	OTHER
2	<input type="checkbox"/>	DF < HP > CONV	CONV
3	<input type="checkbox"/>	HC < TSTATS > HP	HC
4	<input type="checkbox"/>	O < RV > B	O
5	<input type="checkbox"/>	OAS < STAGING > TIMER	TIMER
6	<input type="checkbox"/>	OFF < 50% RULE > ON	OFF
7	<input type="checkbox"/>	OFF < SAS > ON	OFF
8	<input type="checkbox"/>	GAS < FAN > HYDRONIC	GAS

HP < SYSTEM > OTHER - Type of **HVAC system** you want to control. Select **HP**, if your system is any type of Heat Pump. Select **OTHER**, if your system is Hydronic/Electric and/or Standard Cooling.

DF < HP > CONV - If HP is selected **type of Heat Pump** you want to control. Select **DF** (*Restricted Mode*) locks out the compressor during auxiliary heat operation. Select **CONV** (*Unrestricted Mode*) if you wish to have the compressor run during auxiliary heat operations.

HC < TSTATS > HP - Select **HC** for regular **Heat/Cool** thermostats, select **HP** for Heat Pumps. **IMPORTANT NOTE:** *True thermostatic staging is not available when using 2 Stage compressors, it is advisable to use single stage Heat/Cool or HP thermostats and allow the zone panel to stage via the on-board timer.*

O < RV > B - Select the correct **Reversing Valve** signal for your particular Heat Pump. Choose "O" for any Heat Pump that energizes the RV in the cooling mode. Choose "B" for any Heat Pump that energizes the RV in heating mode.

OAS < STAGING > TIMER - Select **OAS**, if you want to delay auxiliary heat based on the outside air temperature sensor. Select **TIMER**, if you want to delay staging heat & cool based on the adjustable on-board timer. **NOTE:** 'Y2' output defaults to a 30 minute delay, when OAS is chosen. An optional Outside Air Sensor (OAS) is required to use the OAS feature.

OFF < 50% RULE > ON - Select **OFF**, if you **do not want** to inhibit Y2 and/or auxiliary heat based on the total number of zones calling. Select **ON**, if you **want to** inhibit Y2 and/or auxiliary heat based on the total number of zones calling. More than half the total zones must be calling for the same mode of operation (*heat or cool*), or the zone panel will not stage up. The 50% rule will always dominate the staging timer and thermostat demands unless Emergency mode is active.

OFF < SAS > ON - Select **OFF**, if you do not want to use the supply air sensor for the Zone Control system. Select **ON**, if you intend to use an optional *supply air sensor (SAS)*.

GAS < FAN > HYDRONIC - **NOTE:** The indoor fan mode is automatically set for you. There is no need to move this switch when setting up for operations.

Seven Built-in Timers for Safe & Reliable Operation

** During set-up momentarily pressing the **RESET Button** clears the built-in timers. Pressing the **RESET Button** for 7 seconds will reset the CPU.

- * Start-up Delay Timer = 3 minutes-fixed
- * Short Cycle Timer = 3 minutes-fixed
- * Change Over Timer = 4 minutes-fixed
- * Opposing Call Timer = 20 minutes-fixed
- * Staging Timer = OFF or 7-42 min.-Adj.
- * Supply Air Limit Timer = 3 minutes-fixed
- * Purge Delay Timer = 90 seconds-fixed

Startup Delay Timer - The panel will not activate any cooling or heating operation until the startup delay has expired. Momentarily pressing the **RESET Button** clears the built-in

Continue: Seven Built-in Timers

timers This occurs after any initial power up or power failure. Press the **Reset** button for 1 second to override.

Short Cycle Timer - When all zone demands are satisfied, the panel will not resume the same mode of operation for a minimum of 3 minutes.

Changeover Timer - Prevents the system from rapidly switching between heating and cooling modes. At the end of a call, a 4 minute timer is started and the panel will not switch to the opposing mode until the timer has expired.











Opposing Call Delay - A 20 minute delay must expire, or the active zone(s) must satisfy, before the panel will honor a demand to changeover to the opposite mode of system operation.

Staging Timer/OAS - The STAGING TIMER sets the amount of continuous call time in 1st stage, before second stage heat or cool is energized. **NOTE: The potentiometer also serves as the Outside Air Changeover Setting.**

Purge Delay - The STAGING TIMER sets the amount of continuous call time in 1st stage, before second stage heat or cool is energized. **NOTE: The potentiometer also serves as the Outside Air Changeover Setting**

Zoning Panel LED's

The 11 function specific LED's that indicate HVAC system operation and zone damper status. Familiarize yourself with the LED functions and definitions, in order to accurately determine the Zoned HVAC system status and mode of operation.

- | | | | |
|---|--|--|--|
|  STATUS | The STATUS LED pulses as a steady heart beat to indicate proper Micro-processor system status. |  FAN | The FAN LED: Indicates a demand for fan operation, during COOLING, HEATING, PURGE, or CONTINUOUS FAN operations. |
|  OAS | The OAS LED illuminates solid to indicate that the Outdoor Temperature has fallen below the chosen set point. The OAS LED will blink rapidly to indicate a shorted or open Outdoor Air Sensor circuit. |  Y2 | The Y2 LED: Indicates the 2nd stage of DX COOLING or DX HEATING is energized. |
|  SAS | The SAS LED illuminates solid to indicate that the Supply Temperature has exceeded the chosen set point on either the HIGH TEMP LIMIT or the LOW TEMP LIMIT. The SAS LED will blink rapidly to indicate a shorted or open Supply Air Sensor circuit. |  Y1 | The Y1 LED: Indicates the 1ST stage of DX COOLING or DX HEATING is energized. |
|  ZONE 3 | The ZONE 3 LED: Indicates that damper(s) is energized open, and the Zone is active. |  W1/B | The W1/B LED: Indicates that the 1st stage of HEATING is energized in Gas/Hydronic mode. The W1/B LED also illuminates when 'B' reversing valve is energized in HEAT PUMP operation. <i>NOTE: In Heat Pump Operation, this LED will stay illuminated after the call for heat is completed.</i> |
|  ZONE 2 | The ZONE 2 LED: Indicates that damper(s) is energized open, and the Zone is active. |  W2/E | The W2/E LED: Indicates 2nd or 3rd stage of HEATING is energized in GAS/HYDRONIC or HEAT PUMP mode. The W2/E LED also illuminates when EMERGENCY HEAT is energized in HEAT PUMP mode. |
|  ZONE 1 | The ZONE 1 LED: Indicates that damper(s) is energized open, and the Zone is active. | | |

Zone Controller Breakdown

Expansion Zone Control for 4 - 5 Zones **

** Expansion Zone Control is installed in 4 zones unit only

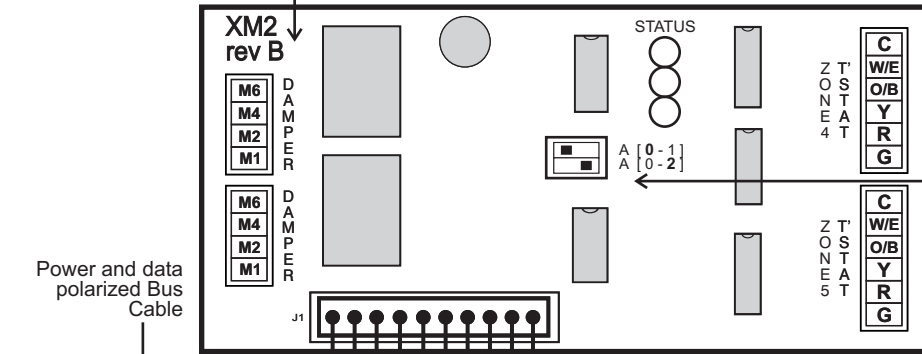

DIP switch settings for 1st Expansion panel. Zones 4 & 5



Power and data polarized Bus Cable

Main Zone Controller

Future Supply Air and Outdoor Air Sensor Connections

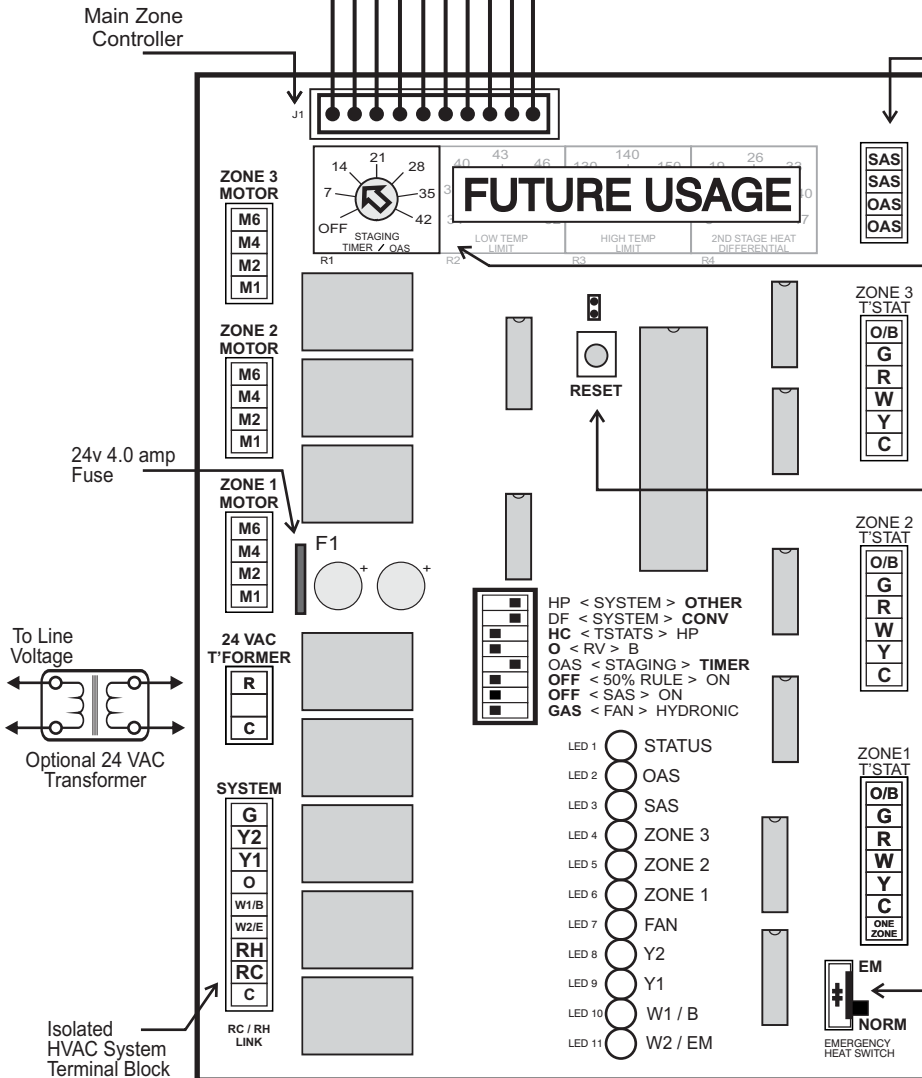

STAGING TIMER (W2/E AND Y2 OUTPUT)

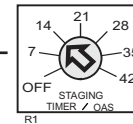

OFF, 7 - 42 minutes or OFF, 7 - 42 degrees F.

Any Setting below 7 is OFF!

DO NOT set to - OFF - when using OAS

Pressing the **RESET Button** for 7 seconds will reset the CPU for the entire zone system Reset the CPU anytime you change the dip switch settings.

Momentarily pressing the **RESET Button** clears the built-in timers, this enables you to test the installation faster. The built-in timers controls the:

- Start-up delay timer
- Short cycle timer
- W2 timer
- Staging timer
- Changeover timer.

** Caution should be observed when using this button.

Emergency Heat Switch

24v 4.0 amp Fuse

To Line Voltage

Optional 24 VAC Transformer

Isolated HVAC System Terminal Block

ZONE DAMPER LOCATIONS AND PLENUM TAKE-OFF SIZES

HE-Z Zone Package Add-Ons - 2, 3 or 4 Collars

The Zoning Add-On package includes pre-wired zone panel and 2, 3 or 4 collars, each w/ power open/close dampers and actuators installed. These are currently available pre-installed on our HE-Z Series Fan Coils. Order HE-Z fan coil unit from our Standard Price List and add these multi-outlet tops to your order as a separate part.

The plenum take-off outlets are 7" in height and adds to the height of the 32" fan coil. The fan coil can be installed in the high boy, counter flow or horizontal position. When you are designing the individual zones try to design each zone to have equal amount of vents and load.

Zone Plenum Sizes

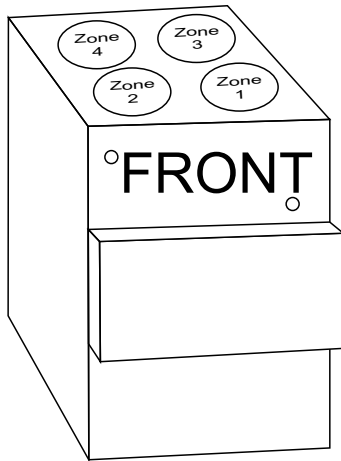
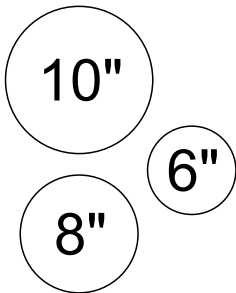

HE-Z-100-(**)-(***V)
c/w HE-Z-100-Z4

** = BU (Blower Unit or
H c/w Hot Water Coil)
*** = 110v or 220v

HE-Z-50-Z2

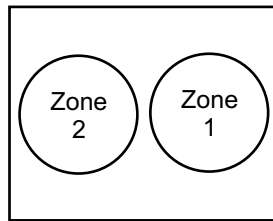

FRONT
2 - 8"

HE-Z-50-Z3

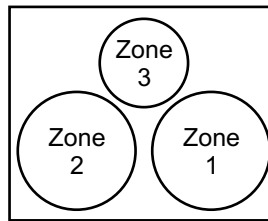

FRONT
2 - 8", 1 - 6"

HE-Z-50-Z4

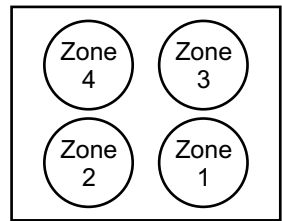

FRONT
4 - 6"

HE-Z-70-Z2

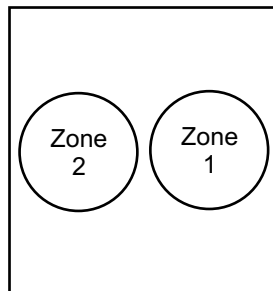

FRONT
2 - 8"

HE-Z-70-Z3

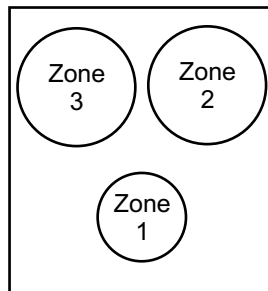

FRONT
2 - 8", 1 - 6"

HE-Z-70-Z4

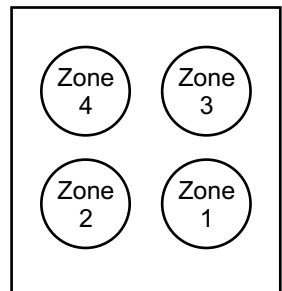

FRONT
4 - 6"

HE-Z-100-Z2

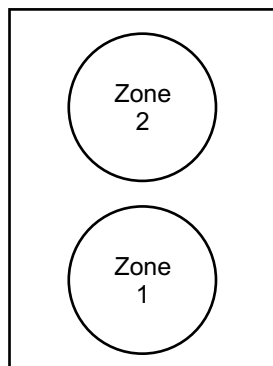

FRONT
2 - 10"

HE-Z-100-Z3

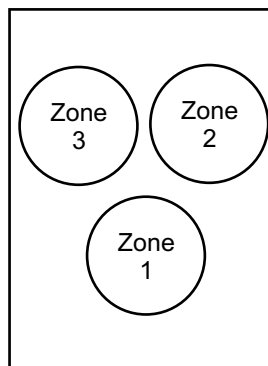

FRONT
3 - 8"

HE-Z-100-Z4

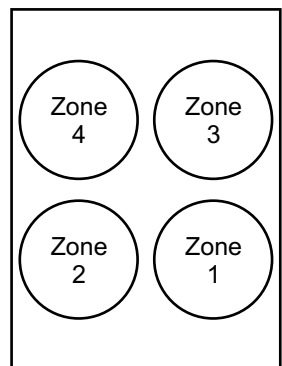

FRONT
4 - 8"

Damper Adjustment

Zone Dampers Adjustment Stops

The **Adjustment Stops** on the actuators have been preadjusted with approximately 10% bleed through. This allows for air to circulate in a non-calling zone. This can be adjusted by adjusting the “0” stop limit.

Balancing Zones

In the case that there is too much pressure through a calling zone (usually a smaller zone on the system) the damper can be adjusted partially closed. Partially closing a damper will cause back pressure on the blowers pressure control and the fan coil will slow down the motor. Adjust the “1” stop to limit the actuators opening to the level of pressure/air required for the air flow desired for the smaller zone.

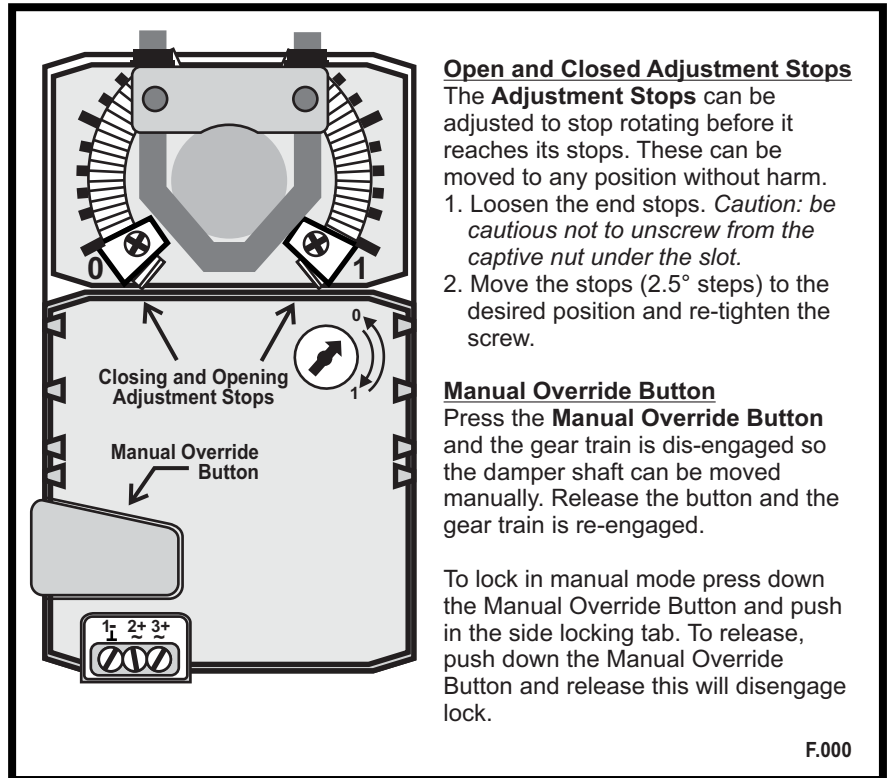

Zone damper Wiring

The zone dampers on the HE-Z Zoning Fan Coil comes pre-wired. There are Seven Built-in Timers that over ride the operation of the zone dampers and output signals of the zone board these are shown on pages 2 and 3.

ZONE DAMPER WIRING

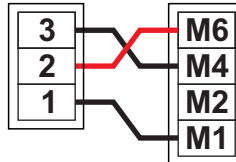

M6 - 24vac Closes damper
M4 - 24vac Opens damper
M2 - Constant 24 vac HOT
M1 - Common 24 vac

Constant Fan Comfort

Having the fan switch at the thermostat to the “ON” position is strongly recommended. This utilizes continuous air circulation for optimal Indoor Air Quality (IAQ) and Energy Efficiency. Independent testing has shown that utilizing the recirculating fan with the Hi-Velocity Systems VFD motor reduces total energy usage. This is due to less on/off cycling of AC and Heating equipment by constant de-stratification of the air.

The zone controller board will default the actuators in the open position when there is no call for constant fan, heat or cooling. If one of the zones is calling for constant fan and the others are not, the zones that are not calling will close.

In the event of a zone calling for heat or cooling the zone dampers (regardless if a zone is calling for constant fan) will close the non-calling heat/cool zones. The actuators have been pre-adjusted with approximately 10% bleed through, this allows for air to circulate in a non-calling zone. With the 10% by-pass it will not over heat or cool a non-calling zone if the other zones are calling heat or cooling but will add comfort as the air will not be stagnate in the non-calling zone and will supply more even air temperatures throughout.

Damper Wiring and Configuration

Dampers default to the "OPEN" position

- When all zone demands are satisfied with no signals from the thermostats.
- After a purge delay
- During change over
- Short cycle delays

From factory the fan coil is pre-wired for two stage cooling. If single stage cooling is desired the fan coils controls will need to be re-wired. Below are the required changes.

Follow the HE-Z Fan coils main Installation Manual for wiring the PSB to the system.

SINGLE STAGE CONDENSING UNIT

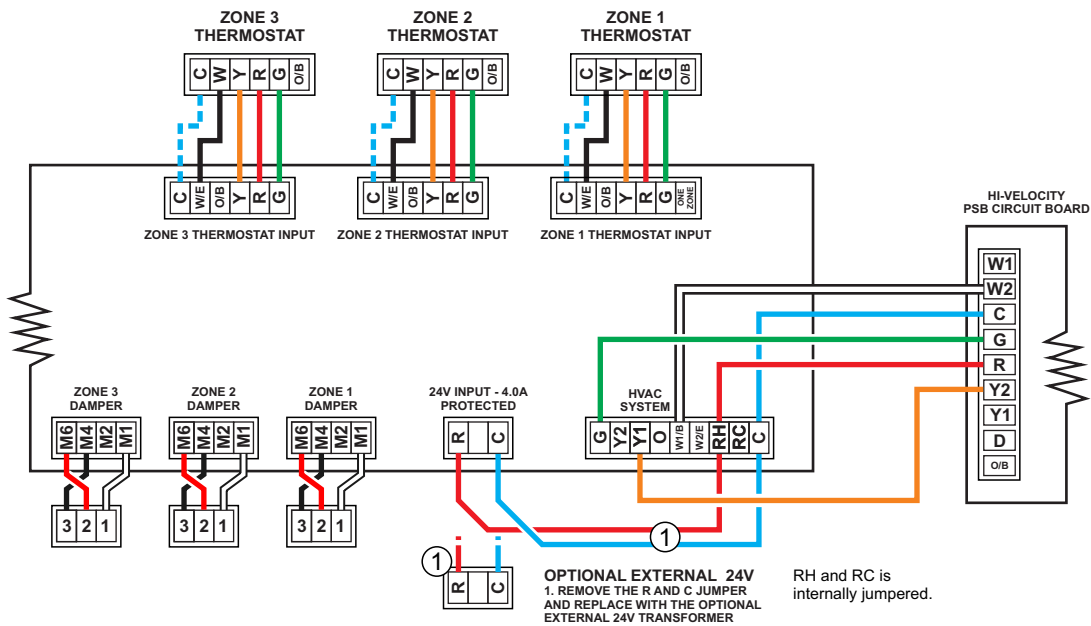

TWO STAGE OR VARIABLE SPEED CONDENSING UNIT

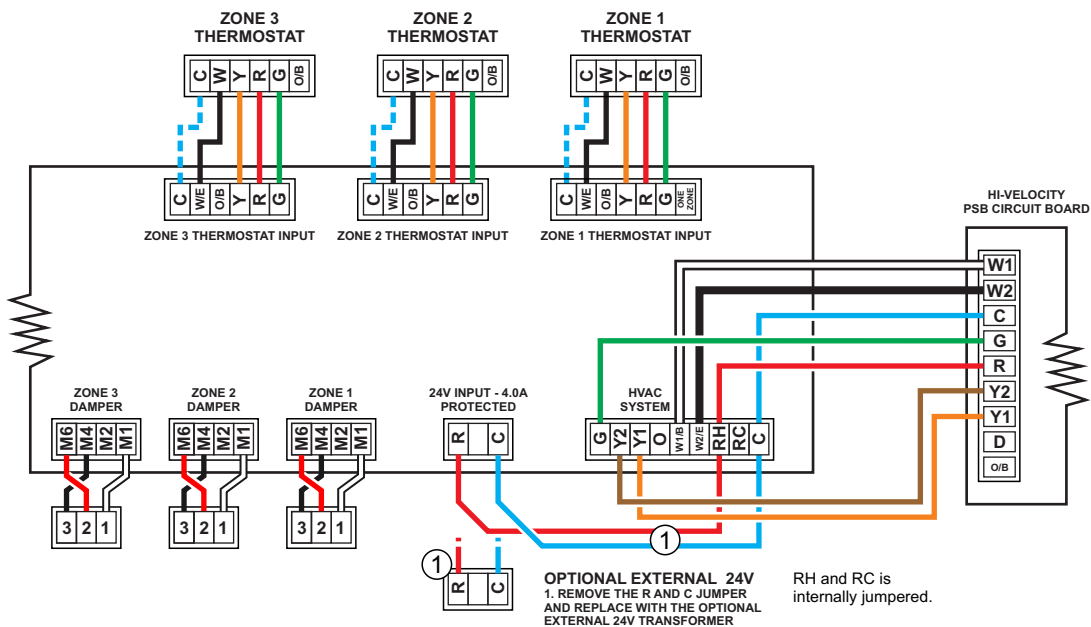

PSB / VFD

POWER INPUT: 110-127/1/50-60

THERMOSTAT CONNECTIONS

- R - 24 VAC OUTPUT
- W1 - FIRST STAGE HEAT
- W2 - SECOND STAGE HEAT (OR SINGLE STAGE)
- Y1 - FIRST STAGE COOLING
- Y2 - SECOND STAGE COOLING (OR SINGLE STAGE)
- C - 24 VAC COMMON
- G - THERMOSTAT FAN SWITCH
- D - PRIORITY (RUNS AT W SPEED)
- O/B - HEATPUMP REVERSING

EMERGENCY DISCONNECT

- C - 24 VAC COMMON
- C - 24 VAC COMMON
- Ro - 24 VAC OUTPUT
- Ri - 24 VAC INPUT
- AUXILIARY HEATING RELAY
- N - NEUTRAL
- L - LINE VOLTAGE
- A1 - AUXILIARY NORMALLY OPEN
- A2 - AUXILIARY NORMALLY CLOSED
- A3 - AUXILIARY COMMON

24 VAC OUTPUT CONNECTIONS

- FZ - FREEZE STAT
- FZ - FREEZE STAT
- W1 - HEATING (W1) 24 VAC OUTPUT
- W2 - HEATING (W2) 24 VAC OUTPUT
- Y2 - CONDENSING UNIT 24 VAC OUTPUT
- Y1 - CONDENSING UNIT 24 VAC OUTPUT
- C - 24 VAC COMMON
- R - 24 VAC OUTPUT

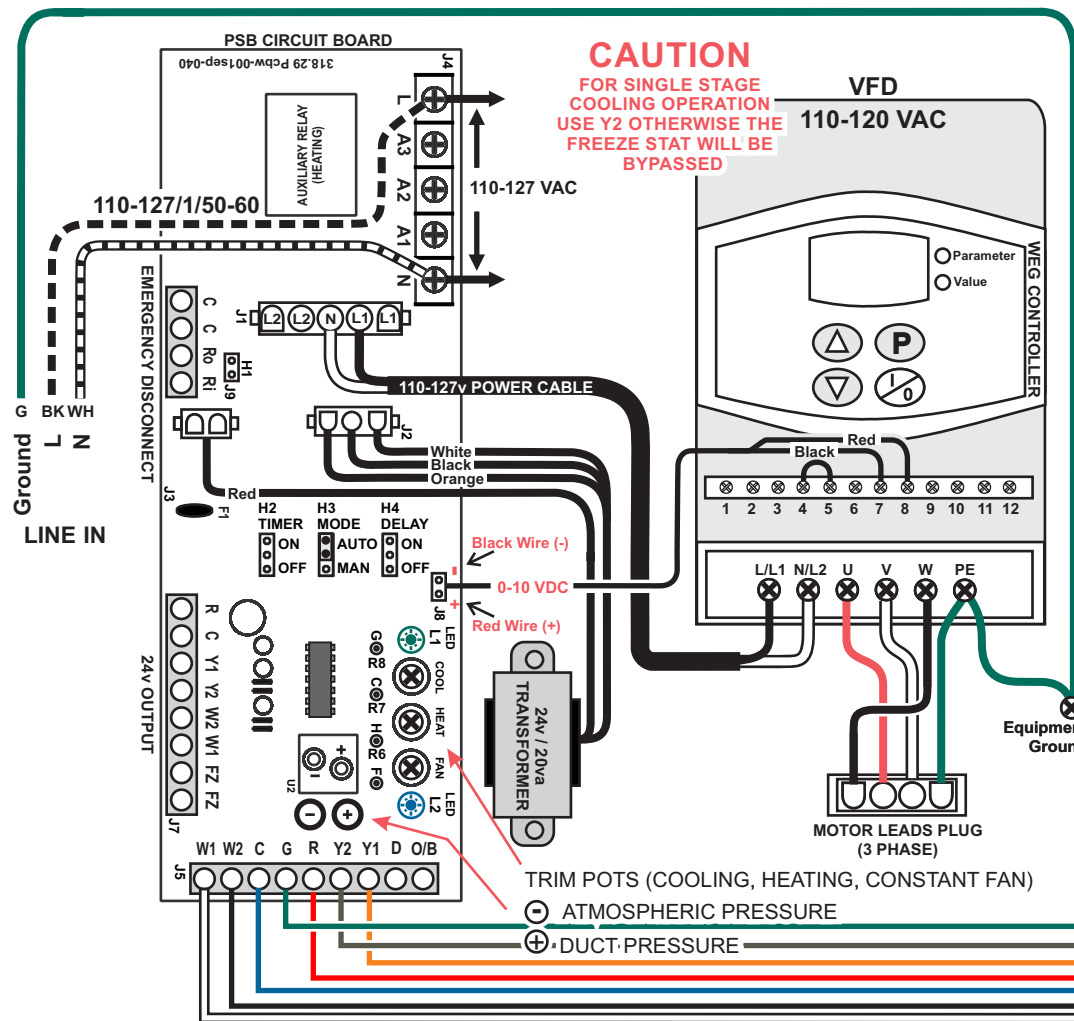

Expansion Zone Control SUPPLIED WITH 4 ZONE OPTION ONLY

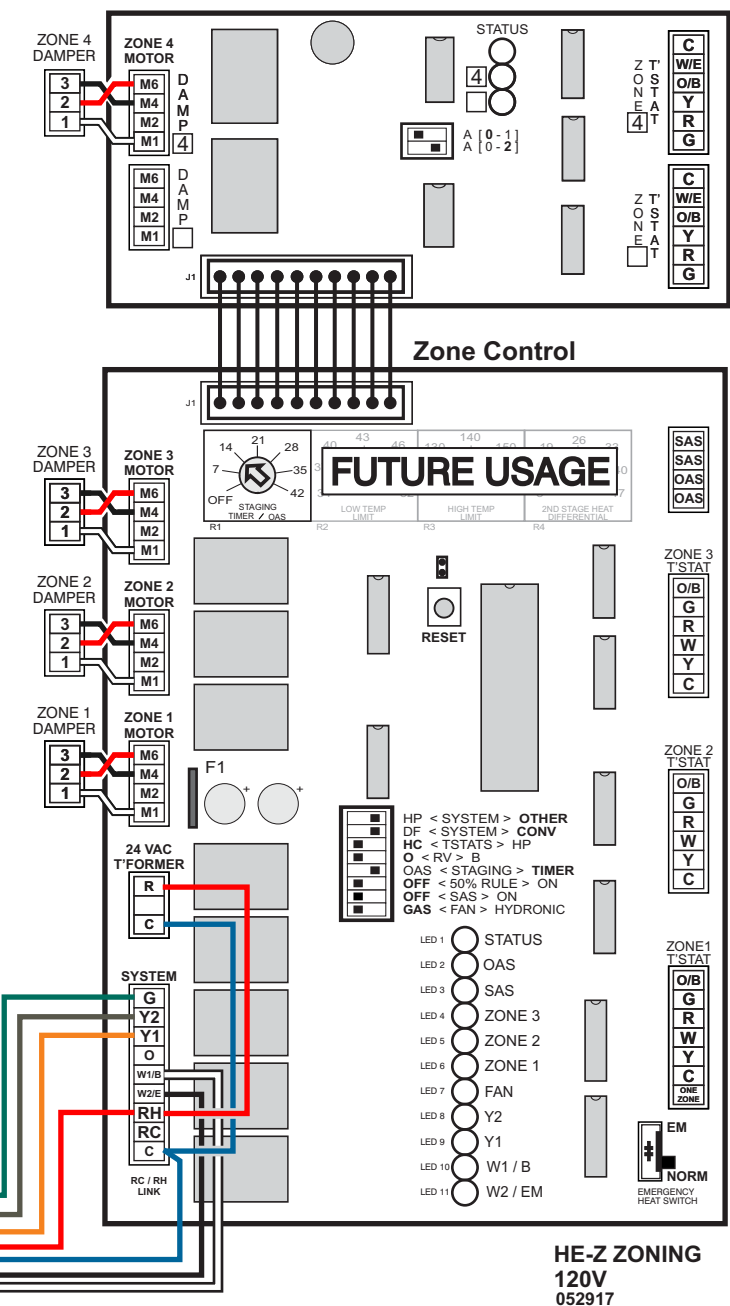

PSB / VFD

POWER INPUT: 200-240/1/50-60

THERMOSTAT CONNECTIONS

- R - 24 VAC OUTPUT
- W1 - FIRST STAGE HEAT
- W2 - SECOND STAGE HEAT (OR SINGLE STAGE)
- Y1 - FIRST STAGE COOLING
- Y2 - SECOND STAGE COOLING (OR SINGLE STAGE)
- C - 24 VAC COMMON
- G - THERMOSTAT FAN SWITCH
- D - PRIORITY (RUNS AT W SPEED)
- O/B - HEATPUMP REVERSING

EMERGENCY DISCONNECT

- C - 24 VAC COMMON
- C - 24 VAC COMMON
- Ro - 24 VAC OUTPUT
- Ri - 24 VAC INPUT

AUXILIARY HEATING RELAY

- N - NEUTRAL
- L - LINE VOLTAGE
- A1 - AUXILIARY NORMALLY OPEN
- A2 - AUXILIARY NORMALLY CLOSED
- A3 - AUXILIARY COMMON

24 VAC OUTPUT CONNECTIONS

- FZ - FREEZE STAT
- FZ - FREEZE STAT
- W1 - HEATING (W1) 24 VAC OUTPUT
- W2 - HEATING (W2) 24 VAC OUTPUT
- Y2 - CONDENSING UNIT 24 VAC OUTPUT
- Y1 - CONDENSING UNIT 24 VAC OUTPUT
- C - 24 VAC COMMON
- R - 24 VAC OUTPUT

Expansion Zone Control SUPPLIED WITH 4 ZONE OPTION ONLY

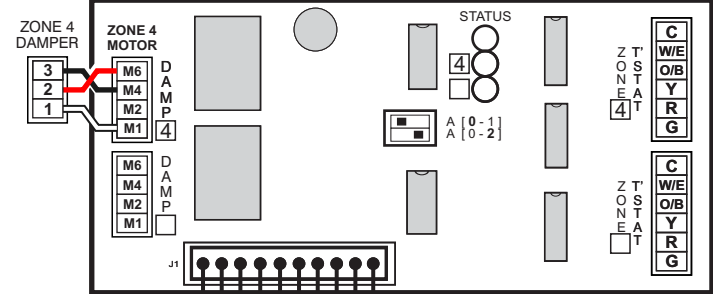

Zone Control

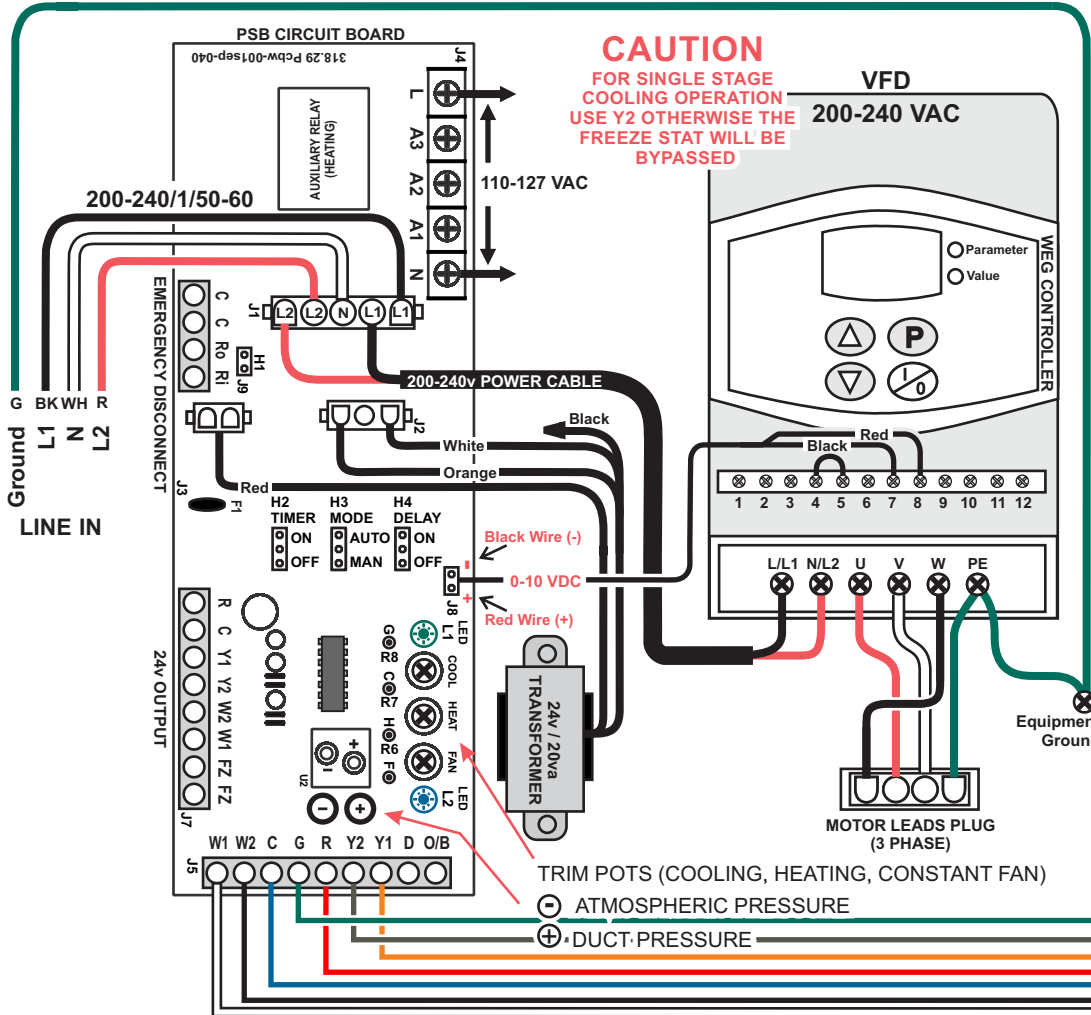
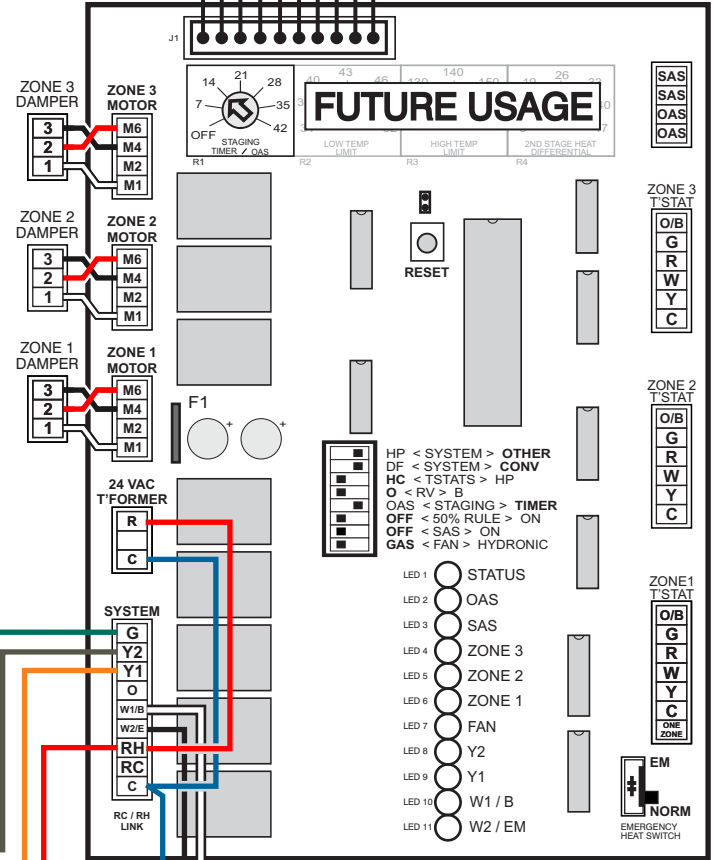

HE-Z ZONING
220V
052917

Wiring and Configuration

JUMPER PIN SETTINGS

H1 EMERGENCY DISCONNECT: REMOVE PIN IF WIRED TO EMERGENCY DISCONNECT.

H2 TIMER: AUXILIARY RELAY TIMER (SEE NOTES).

H3 MODE:

AUTO - FAN SPEED MODULATES DEPENDING UPON STATIC PRESSURE.

MANUAL - FAN SPEED OPERATES AT TRIM POTS SET AIR FLOW.

H4 DELAY: Y/20 AND W/30 SECOND FAN DELAY. Y AND W 30 SECOND POST PURGE.

LED LIGHT INDICATORS

LED 1 - GREEN LIGHT, PUMP TIMER AND OPERATION MODE INDICATOR.

LED 2 - BLUE LIGHT, PRESSURE SENSOR.

ZONE BOARD SEVEN BUILT-IN TIMERS FOR SAFE & RELIABLE OPERATION

** DURING SET-UP MOMENTARILY PRESSING THE **RESET** BUTTON CLEARS THE BUILT-IN TIMERS. PRESSING THE **RESET** BUTTON FOR 7 SECONDS WILL RESET THE CPU.

STARTUP DELAY TIMER - THE PANEL WILL NOT ACTIVATE ANY COOLING OR HEATING OPERATION UNTIL THE STARTUP DELAY HAS EXPIRED. MOMENTARILY PRESSING THE **RESET** BUTTON CLEARS THE BUILT-IN TIMERS. THIS OCCURS AFTER ANY INITIAL POWER UP OR POWER FAILURE. PRESS THE **RESET** BUTTON FOR 1 SECOND TO OVERRIDE.

- * START-UP DELAY TIMER = 3 MINUTES-FIXED
- * SHORT CYCLE TIMER = 3 MINUTES-FIXED
- * CHANGE OVER TIMER = 4 MINUTES-FIXED
- * OPPOSING CALL TIMER = 20 MINUTES-FIXED
- * STAGING TIMER = OFF OR 7-42 MIN.-ADJ.
- * SUPPLY AIR LIMIT TIMER = 3 MINUTES-FIXED
- * PURGE DELAY TIMER = 90 SECONDS-FIXED

ZONE CONTROLLER

PRE-WIRED TO 2 ZONES, 3 AND 4 IF APPLICABLE

- M6 - 24VAC TO CLOSE DAMPER
- M4 - 24VAC TO OPEN DAMPER
- M2 - CONSTANT 24 VAC HOT
- M1 - COMMON 24 VAC

NOTES:

- 1) USE THERMOSTAT FAN SWITCH TO DISABLE/ENABLE CONTINUOUS FAN.
- 2) 'C' TERMINAL ON THERMOSTAT (COMMON) IS NOT NEEDED FOR SOME THERMOSTATS CONSULT THERMOSTAT INSTRUCTIONS FOR DETAILS.
- 3) W1 AND W2 ACTIVATES AUXILIARY RELAY (A3) ON CALL AND CAN BE USED WITH A1 AND/OR A2 AS DRY CONTACTS, ARMED 24VAC FROM THE 'R' TERMINAL, OR ARMED 110v FROM THE 'L' TERMINAL.
- 4) AUXILIARY HEATING RELAY TIMER ACTIVATES CIRCUIT FOR 5 MINUTES EVERY 24 HOURS STARTING WHEN POWER IS APPLIED TO THE UNIT.
- 5) **LED 1: INDICATOR LIGHT FOR FAN SPEED OPERATION AND AUXILIARY RELAY OPERATION.** SEE BELOW FOR LIGHT OPERATION SEQUENCE.
- 6) SEE INSTALLATION MANUAL FOR MORE DETAILED WIRING DIAGRAMS.
- 7) **FOR SINGLE STAGE COOLING OPERATION USE Y2, OTHERWISE THE FREEZE STAT WILL BE BYPASSED.**
- 8) FAILURE TO SET PROPER AIR FLOW AND/OR OPERATION OF THE SYSTEM MAY RESULT IN DAMAGE TO EQUIPMENT.
- 9) FAILURE TO READ AND FOLLOW ALL INSTRUCTIONS CAREFULLY BEFORE INSTALLATION COULD CAUSE PERSONAL INJURY AND/OR PROPERTY DAMAGE.
- 10) ENSURE THAT THE FILTER IS KEPT CLEAN AT ALL TIMES.
- 11) MOTOR HAS PERMANENT LUBE BEARINGS AND DOES NOT REQUIRE OILING.
- 12) WARRANTY VOID IF FAN COIL UNIT IS USED DURING CONSTRUCTION.

LED 1: (GREEN LIGHT)

PUMP TIMER/OPERATION MODE INDICATOR LIGHT SEQUENCE

PUMP TIMER STATUS		FAN OPERATION MODE
ON: (ACTIVE)		G
ON: (INACTIVE)		W
OFF:		Y
		D
2 SECONDS	2 SECONDS	2 SECONDS

LED 2: PRESSURE SENSING INDICATOR (BLUE LIGHT)

H3 JUMPER PIN: AUTO OR MANUAL MODE

AUTO MODE: LED 2 WILL SPORADICALLY FLICKER (ON/OFF)

TO SHOW THAT IT IS PROPERLY SENSING PRESSURE IN THE SYSTEM.

* **NO LIGHT** INDICATES TRIM POT IS ABOVE NORMAL OPERATING RANGE (COUNTER CLOCKWISE DECREASE).

* **SOLID LIGHT** INDICATES TRIM POT IS BELOW NORMAL OPERATING RANGE (CLOCKWISE, INCREASE).

MANUAL MODE: LED 2 WILL BE OFF, ADJUST EACH OF THE AIR FLOWS TO DESIRED CFM/LPS OUTPUT.

FAN ADJUSTMENT TRIM POTS



INCREASE AIR FLOW
(CLOCKWISE)



DECREASE AIR FLOW
(COUNTER CLOCKWISE)

ADJUSTING TRIM POTS: ON POWER START UP, ALLOW 45 SECONDS FOR SYSTEM TO PRESSURIZE BEFORE MAKING ANY CHANGES.

DO NOT ADJUST MORE THAN A 1/2 TURN AT A TIME, ALLOW 30 SECONDS BETWEEN ADJUSTMENTS FOR THE PSB TO REACH SET POINT.

REFER AND COMPLETE COMMISSIONING REPORT PRIOR TO NORMAL OPERATION. FOR FULL DETAILS, REPORT IS AVAILABLE IN THE INSTALLATION MANUAL OR ONLINE AT WWW.HI-VELOCITY.COM.